

BIOWRAP[®]

SMARTER WEARABLE TECHNOLOGY[®]

Quick Reference Guide

FOOT-ANKLE BIOWRAP

SILVER

Compression Electrode Garment

Utilizes Advanced Silver Fabric
Electrode Technology



See video at
<https://biowave.com/support-biowraps/>



NOTE: ONLY for use with BioWaveHOME & BioWavePRO.

Questions? Call us!

1-877-BIOWAVE • (1-877-246-9283)

support@biowave.com

Size

	Shoe Size
S / M	Women: 6-10, Men: 5-9
L / XL	Women: 11-16, Men: 10-15

THIS PACKAGE CONTAINS

- One Foot-Ankle BioWrap Compression Electrode Garment - for use on LEFT or RIGHT foot and ankle.
- One 4.2 oz. Bottle of TheraCream Conductive Cream
- Two Spare Replacement Snap Cables

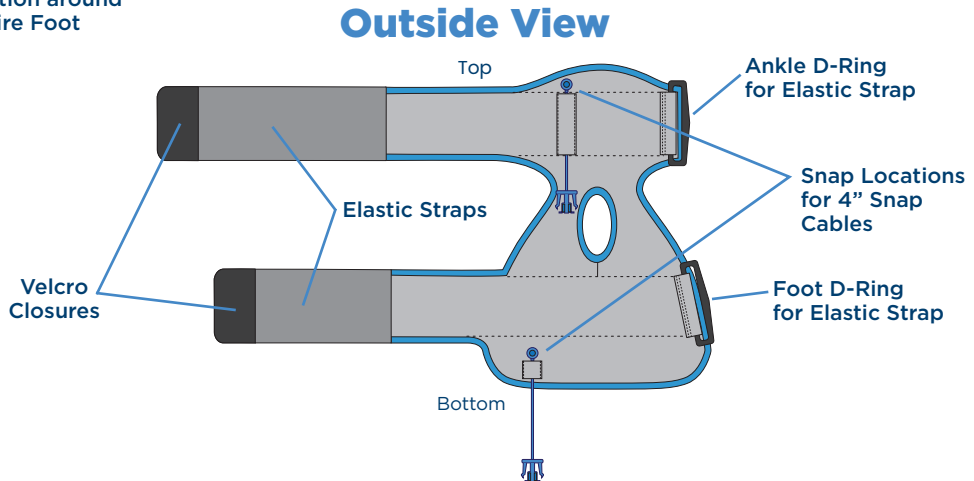
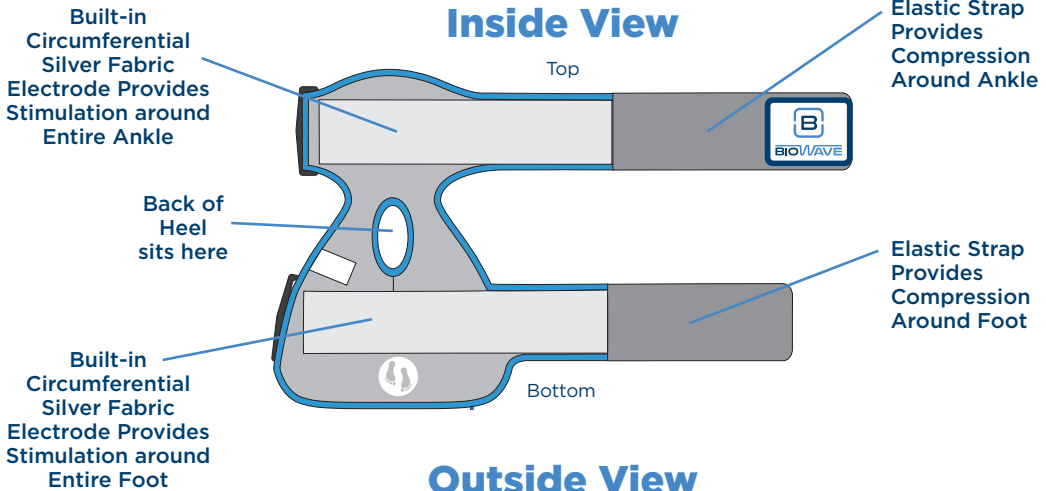

STEPS BEFORE FIRST USE

1. **BEFORE FIRST USE:** First Attach BioWrap to your Body **WITHOUT TheraCream** to make sure the size is correct. If BioWrap is too small or too large, **DO NOT** start a treatment. Immediately contact your provider or BioWave Customer Service at 1-877-BIOWAVE (1-877-246-9283) so we can send you the correct size.
2. **BEFORE FIRST USE:** If the size is correct, remove both snap cables, **HAND WASH SILVER FABRIC** with mild soap and water, rinse, pat dry with towel, then let air dry completely. Once dry, reattach both snap cables to the backside of the BioWrap as shown on the prior page.

DIRECTIONS FOR USE

Step 1. TheraCream Application

- First clean skin with soap and water around the foot and ankle.
- Use a generous pea-sized amount of TheraCream, for EACH of the two SILVER fabric electrodes (SEE PHOTO to the right).
- Rub the TheraCream **INTO THE SKIN** in the area under each SILVER fabric electrode. If you cannot reach your feet, use the TheraCream **Applicator (sold separately)** to rub the TheraCream into your foot and ankle. (SEE PHOTOS to the right).
- **DO NOT** rub TheraCream onto the SILVER fabric electrode.
- TheraCream should be absorbed into the skin without leaving a white coating.
- It is fine to spread TheraCream beyond the electrode area, as long as it is evenly distributed under the SILVER fabric electrodes.

1.



First clean skin around foot and ankle.

Squeeze a generous pea size amount of TheraCream onto your **finger tip or onto the Applicator (sold separately)** and rub into your skin thoroughly around **the entire foot and ankle in the locations that the SILVER FABRIC will touch your skin.**



DIRECTIONS FOR USE

Step 2. Attach Leadwire Cable and BioWrap

These instructions are for attaching the Foot-Ankle BioWrap to the **RIGHT** or **LEFT** foot and ankle. Both 4" Snap Cables should already be snapped onto the 2 snaps on the back side of the BioWrap.

- **Click the blue Snap Cable electrode connectors into the blue Leadwire Cable connectors.**
- **Plug the single end of the Leadwire Cable into the BioWave device** (or dongle attached to the device).

2A.

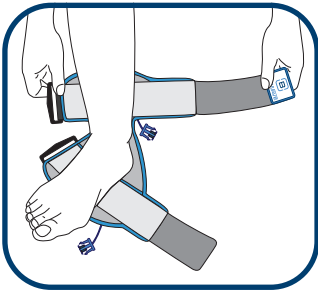

Step onto the foot icon on the bottom of the BioWrap and line up the back of your heel into the hole.

2B.

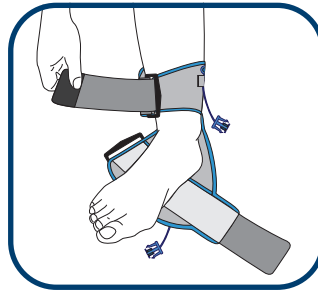

Place top elastic strap through top D-Ring around ankle and pull tight to create strong but comfortable compression just above the ankle.

2C.

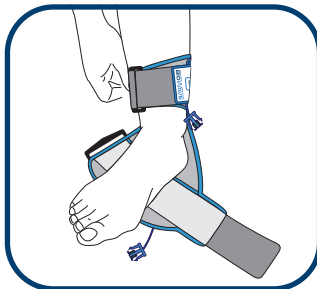

Pull and wrap strap around front and back of ankle to create strong but comfortable compression just above the ankle.

Secure Velcro strap to close.

2D.

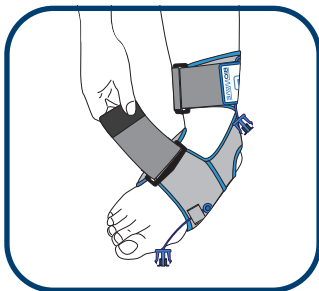

Place bottom elastic strap through bottom D-Ring around foot and pull tight to create strong but comfortable compression around the foot.

2E.

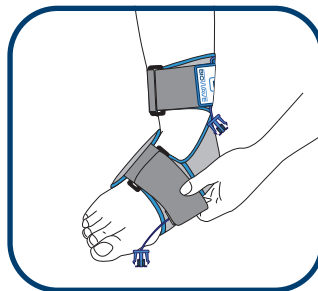

Wrap strap back across top of foot and pull tight to create strong but comfortable compression around entire foot.

Secure Velcro strap to close.

2F.

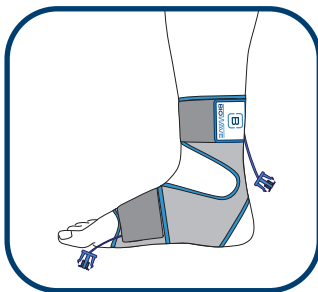

Make sure there are no gaps in the BioWrap anywhere around the entire foot and around the entire ankle.

DIRECTIONS FOR USE

Step 3. Compression Guide

- **Just Right:** Should be snug and comfortable, like a sock. See photo examples below:
- **Too Loose:** Gapping between the silver fabric and skin can lead to an ineffective treatment and a possible intermittent shock or sting.
- **Too Tight:** Can cause stinging near the snap connector, leading to burns.



Just Right/Snug



Too Loose



Too Tight

See video at biowave.com/support/biowrap

Step 4. Treatment

- Press the power button to turn on the BioWave device.
- Start the treatment by pressing the PLUS (+) button to gradually increase intensity so the sensation felt is strong but still comfortable. As your body adapts to the electrical field and the sensation fades, keep pressing the PLUS (+) button to increase the intensity to maintain a strong but **ALWAYS** comfortable sensation at the treatment location.
- **DO NOT** exceed 50% intensity as this may cause discomfort.
- When the 30-minute treatment is over, remove the BioWrap from your body, disconnect the BioWave Leadwire Cable from the two Snap Cable connectors, and store BioWrap in a cool dry place.
- Clean the Silver Fabric Electrodes in your BioWrap after every 2 treatments

Questions?

biowave.com/support/biowrap • support@biowave.com

1-877-BIOWAVE (1-877-246-9283)

TREATMENT TIPS

- Start at a low intensity and gradually increase so sensation is medium strong but still comfortable.
- **DO NOT** increase intensity to >50% as this may cause discomfort. If the sensation is minimal at 50% intensity, **STOP THE TREATMENT**. Clean the skin thoroughly with soap and water, dry the skin with a towel, reapply and rub in slightly more TheraCream to the skin than the first time. Reattach the BioWrap, then gradually increase the intensity. If the sensation is still minimal at 50% intensity, continue the treatment to obtain beneficial results.
- **IF YOU HAVE NO SKIN SENSATION** around your foot and ankle: Increase intensity slowly to 30% over 3 minutes. After 10 minutes, you may increase the intensity as desired by not more than 2% per minute.
- **DO NOT** exceed 50% intensity as this may cause discomfort.
- **NOTE:** If you have a neuropathy, for example, and do not have proprioception (skin sensation), you do not have to feel the sensation of the active electrical field for the device to be working.

CONTRAINDICATIONS

When Not to Use BioWraps

- **DO NOT** use if you have an implanted cardiac pacemaker.
- **DO NOT** place the silver fabric electrodes, located in both straps in the BioWrap, over open wounds, broken skin, rashy skin or sensitive skin areas like sunburned skin.

NOTE:

- BioWrap Wearables **MAY BE PLACED** over or in the proximity of implanted orthopedic hardware, including total joint replacements, anchors, plates, rods, screws, pins and clips.
- Any serious incident that has occurred in relation to the device should be reported to the manufacturer and the competent authority of the Member State in which the user and/or patient is established.

Issues or discomfort? Contact Customer Support:

biowave.com/support/biowrap • support@biowave.com

1-877-BIOWAVE (1-877-246-9283)

TROUBLESHOOTING

1. My BioWave shows a connection error but my BioWrap is plugged in

If your BioWave device shows a connection error when you are fully connected to the BioWrap, remove the BioWrap and follow these steps:

If you forgot to apply TheraCream:

- **CLEAN YOUR SKIN.** Remove BioWrap and clean your skin with soap and water in the region that the silver fabric electrodes touch your skin. Shave any excessive hair in the locations that the silver fabric electrodes touch your skin.
- **APPLY A GENEROUS PEA-SIZE AMOUNT OF THERACREAM** using your fingers or the **Applicator (sold separately)** directly to skin areas that will be against each of the silver fabric electrodes inside the BioWrap. Gently massage TheraCream into the skin allowing it to absorb, before putting on the BioWrap.

If you applied too much TheraCream (excess cream remained on the skin):

- **CLEAN YOUR SKIN.** Remove BioWrap and use a dry towel to remove all excess TheraCream from your skin and any excess cream from the silver fabric in the BioWrap. Next, reattach the BioWrap and begin the treatment.

2. The treatment feels stronger under one electrode versus the other

If the treatment feels stronger under the electrode (for example) around your ankle as compared to around the foot, it may be because the elastic strap around the ankle is too tight and/or the elastic strap around the foot is too loose. Adjust the compression of each strap to increase or decrease the relative sensation during the treatment.

• **Tighter Compression and/or More TheraCream = Stronger Treatment Sensation**

• **Looser Compression and/or Less TheraCream = Less Treatment Sensation**

3. I feel a tingle when the BioWave device is first turned on.

This is normal. When the BioWave device is turned on, you may feel a tingle for one second prior to starting the treatment as the device checks it is properly connected to you.

CLEANING INSTRUCTIONS

CLEAN BEFORE FIRST USE AND AFTER EVERY 2 USES:

1. Remove both snap cables
 2. Hand wash silver fabric with mild soap and water
 3. Rinse
 4. Pat dry with towel
 5. Let air dry completely
 6. Reattach snap cables
- **CLEAN your BioWrap after every 2 treatments**
 - **NEVER** clean using an alcohol or other chemical wipe
 - **DO NOT** clean in a washing machine
 - **DO NOT** dry in a dryer

Questions? Call us!

Technical Support:

1-877-BIOWAVE (1-877-246-9283)

biowave.com/support/biowrap

support@biowave.com



Need help?

Contact us at:

1-877-BIOWAVE • (1-877-246-9283)

support@biowave.com

The information, including but not limited to text, graphics, images and other material contained herein are for informational purposes only. **Learn more at [BioWave.com/terms-of-use](https://www.biowave.com/terms-of-use)**

